

# EURO EVO

Forno elettrico modulare per pizzeria, pasticceria e panetteria

Modular electric oven for pizza, pastry and bread



## EURO EVO - EVC70

### CARATTERISTICHE TECNICHE

#### TECHNICAL SPECIFICATIONS

	Resistenze corazzate Hype inserite nel piano refrattario e resistenze cielo a vista Armored heating elements Hype inserted inside the baking floor and ceiling heating elements exposed
	Camera di cottura totalmente rivestita in materiale refrattario Cooking chamber fully coated with refractory material
	Regolazione digitale separata della potenza cielo e piano di cottura Independent digital power regulation for baking floor and ceiling
	450°C di temperatura massima di cottura Maximum cooking temperature 450°C
	Isolamento termico garantito Guaranteed thermal insulation
	Sportello con finestra in vetro temperato Door with tempered glass window
	Sportelli frontali controbilanciati Counter-balanced front doors
	Visione completa dell'interno della camera di cottura Complete view of the cooking chamber inside

	Illuminazione camera Chamber lighting
	Valvola regolabile per scarico vapori Adjustable steam exhaust valve
	3 forni in 1: Pizzeria, Pasticceria e Panetteria 3 ovens in 1: Pizza, Pastry and Bread
	* Modulo cappa con motore e kit abbattimento vapori e odori opzionali * Hood module with optional motor and vapour and odour removal kit
	Supporto piano portateglie con ruote Tray holder level support with wheels
	Cella di lievitazione con ruote a chiusura ermetica Hermetic seal leavening cell with wheels
	Disponibile con frontale inox Available with stainless steel front

\* OPTIONAL

**ITALFORNI È UN BRAND DI WAICO GROUP**

ITALFORNI - Sede operativa  
Via dell'Industria, 130 - Loc. Chiusa di Ginestreto  
61122 Pesaro (PU) Italia - Tel. +39 0721 481515  
italforni@waicogroup.com - www.italforni.it

WAICO srl - Sede legale  
Via Scotte, 1 - Isola Vicentina  
36033 Vicenza (VI) Italia - Tel. +39 0445 1716598  
info@waicogroup.com - www.waicogroup.com

**1 CAMERA + SUPPORTO ALTO**  
1 DECK + HIGH STAND

✓ ALLACCIO ELETTRICO  
ELECTRIC CONNECTION

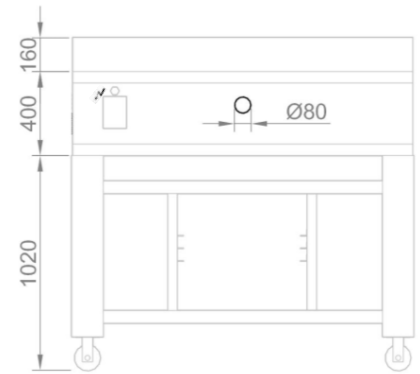
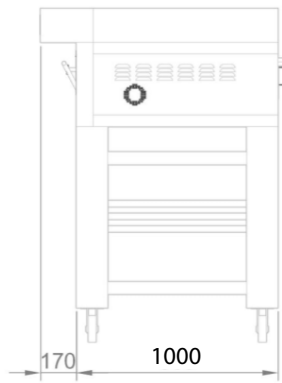
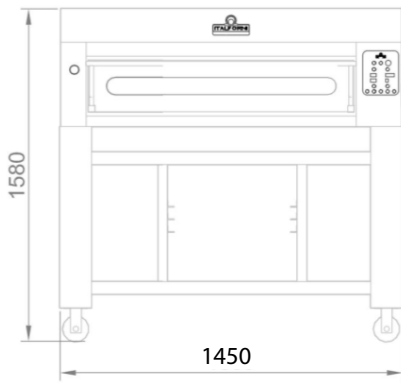

**1 CAMERA + CELLA DI LIEVITAZIONE ALTA**  
1 DECK + HIGH PROVER

✓ ALLACCIO ELETTRICO  
ELECTRIC CONNECTION

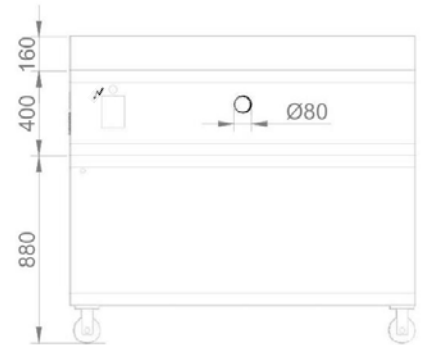
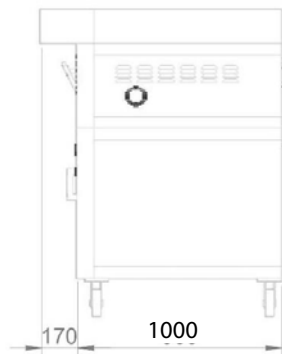
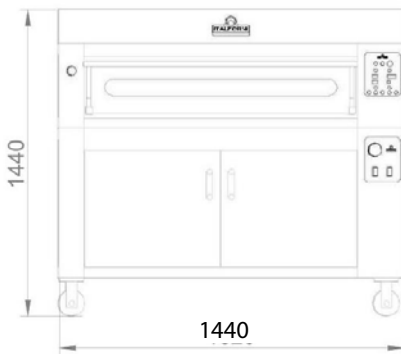

**2 CAMERE + SUPPORTO ALTO**  
2 DECKS + HIGH STAND

✓ ALLACCIO ELETTRICO  
ELECTRIC CONNECTION

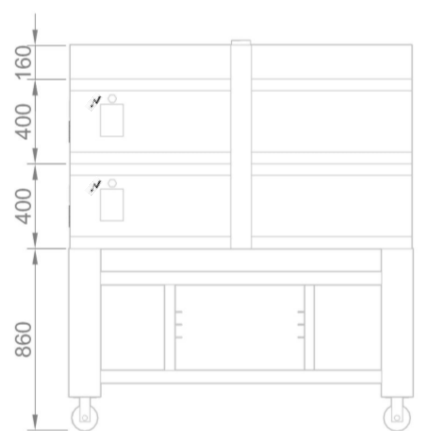
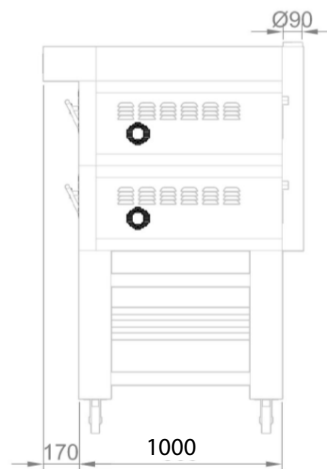
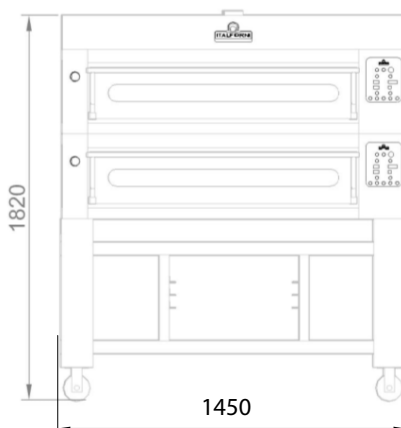

ITALFORNI È UN BRAND  
DI WAICO GROUP

ITALFORNI - Sede operativa  
Via dell'Industria, 130 - Loc. Chiusa di Ginestreto  
61122 Pesaro (PU) Italia - Tel. +39 0721 481515  
italforni@waicogroup.com - www.italforni.it

WAICO srl - Sede legale  
Via Scotte, 1 - Isola Vicentina  
36033 Vicenza (VI) Italia - Tel. +39 0445 1716598  
info@waicogroup.com - www.waicogroup.com

**2 CAMERE + CELLA DI LIEVITAZIONE ALTA**  
2 DECKS + HIGH PROVER

ALLACCIO ELETTRICO  
ELECTRIC CONNECTION

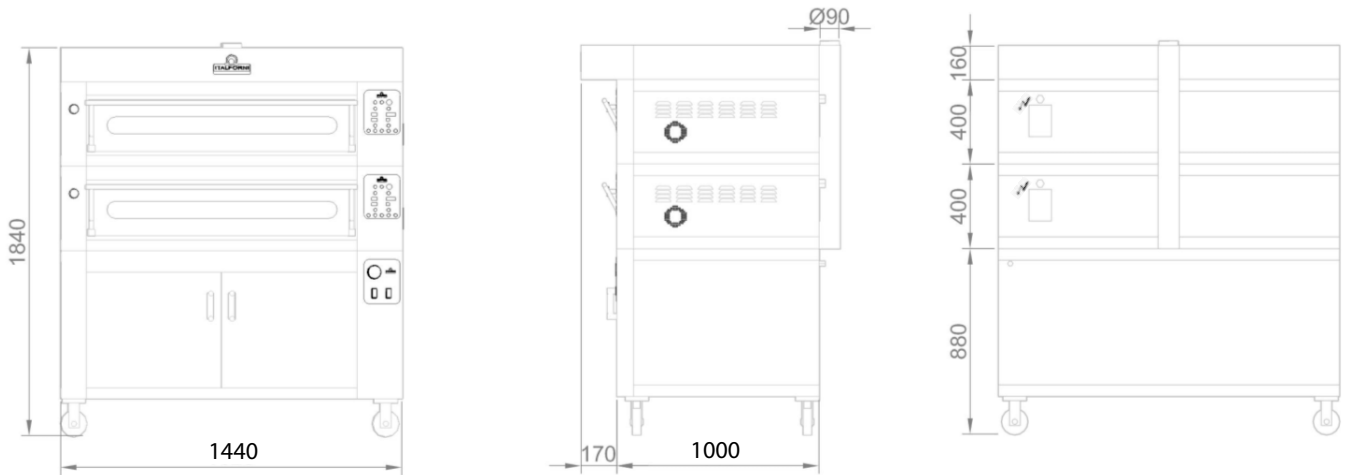

**3 CAMERE + SUPPORTO BASSO**  
3 DECKS + LOW STAND

ALLACCIO ELETTRICO  
ELECTRIC CONNECTION

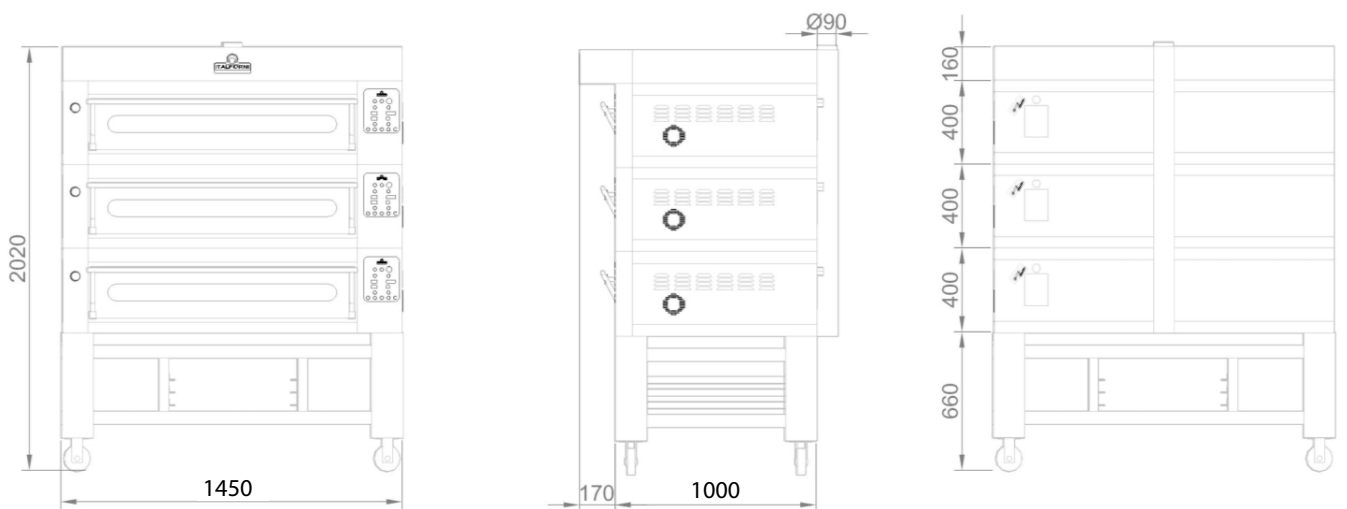

**3 CAMERE + CELLA DI LIEVITAZIONE BASSA**  
3 DECKS + LOW PROVER

ALLACCIO ELETTRICO  
ELECTRIC CONNECTION

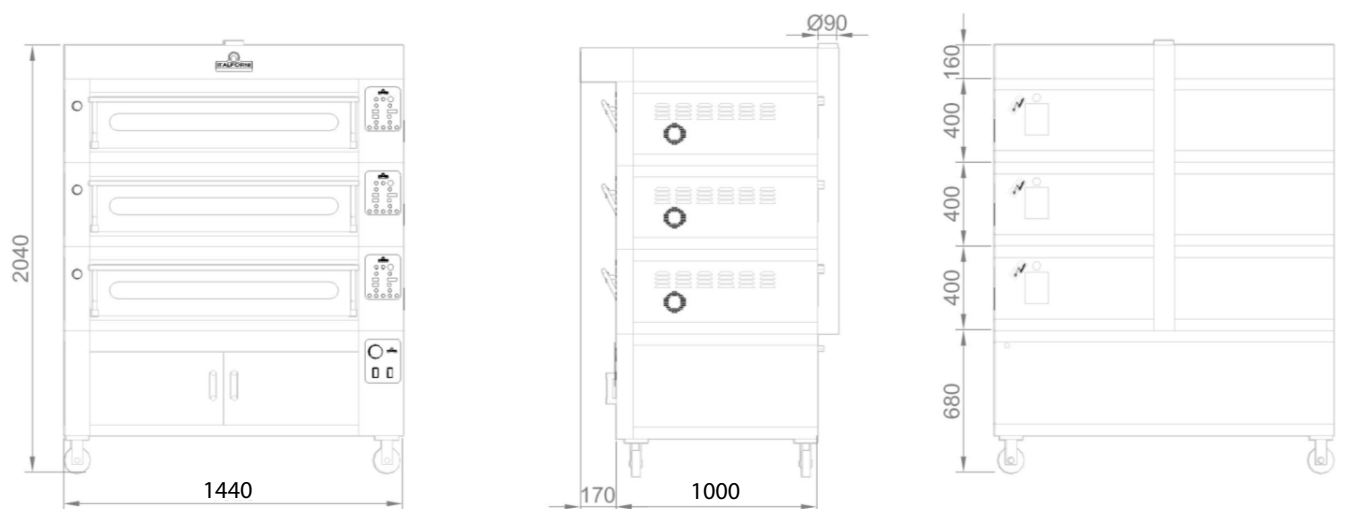

ITALFORNI È UN BRAND  
DI WAICO GROUP

ITALFORNI - Sede operativa  
Via dell'Industria, 130 - Loc. Chiusa di Ginestreto  
61122 Pesaro (PU) Italia - Tel. +39 0721 481515  
italforni@waicogroup.com - www.italforni.it

WAICO srl - Sede legale  
Via Scotte, 1 - Isola Vicentina  
36033 Vicenza (VI) Italia - Tel. +39 0445 1716598  
info@waicogroup.com - www.waicogroup.com

**CAPACITÀ DI CARICO PER CAMERA**  
 LOADING CAPACITY PER DECK

**EVC70**
**DIMENSIONI INTERNE**  
 Internal dimensions  
 A/H 17 x L/W 105 x P/D 70 cm  
 6 Pizze Ø 35 cm  
 2 Teglie 60x40 cm  
 2 Baking pans 60x40 cm

**DATI TECNICI**

## TECHNICAL CHART

EURO	Dimensioni interne (cm) Internal Dimensions (cm)			Dimensioni esterne (cm) External Dimensions (cm)			Peso Weight Kg	Alimentazione Supply V/Ph/Hz		Potenza Power Max. kW / Med. kW/h		Assorbimento Absorption Ampere	Temperatura Temperature °C	N° Pizze # Pizze Ø 30/35 cm	N° Teglie # Baking pans 60x40 cm
	A/H	L/W	P/D	A/H	L/W	P/D									
<b>EVC70</b>	17	105	70	40	144	100	205	400/3/50-60		9	4,5	11	0/450	6 Ø 35	2

**I = Frontale Acciaio Inox - Stainless Steel Front / R = Frontale Rustico - Country Style Front**

CAPPA - HOOD			A/H	L/W	P/D	Kg								
<b>KVC70</b>			16	144	117	18								

CELLA LIEVITAZIONE - PROVER			A/H	L/W	P/D	Kg	V/Ph/Hz	kW	kW/h		°C		60x40 cm
<b>BVC70/I</b>			70/50	144	100	100	230/1/50-60	1	0,5		0/90		6

SUPPORTO - STAND			A/H	L/W	P/D	Kg							60x40 cm
<b>SEVC70</b>			86/70/50	145	100	50/43/36							6

**ITALFORNI È UN BRAND  
DI WAICO GROUP**
**ITALFORNI - Sede operativa**  
 Via dell'Industria, 130 - Loc. Chiusa di Ginestreto  
 61122 Pesaro (PU) Italia - Tel. +39 0721 481515  
 italforni@waicogroup.com - www.italforni.it

**WAICO srl - Sede legale**  
 Via Scotte, 1 - Isola Vicentina  
 36033 Vicenza (VI) Italia - Tel. +39 0445 1716598  
 info@waicogroup.com - www.waicogroup.com

 I dati riportati sul presente documento sono da ritenersi non vincolanti. Waico srl si riserva di apportare modifiche tecniche in qualsiasi momento.  
 The specifics shown in this document are to be considered not binding. Waico srl reserves the right to make technical changes at any moment.