

# EURO EVO

Forno elettrico modulare per pizzeria, pasticceria e panetteria

Modular electric oven for pizza, pastry and bread



## EURO EVO CLASSIC - EVC8

### CARATTERISTICHE TECNICHE

- 1 - 2 - 3 camere di cottura interamente in materiale refrattario con piano di cottura e cielo ad alte prestazioni e resistenza
- Resistenze corazzate "hy-pe" in acciaio inossidabile integrate nel refrattario del piano di cottura e resistenze del cielo a vista
- Pannello di controllo digitale
- Controllo delle potenze del piano di cottura e del cielo separate
- Isolamento termico
- Massima temperatura di cottura 450 °C
- Valvola regolabile per scarico vapori
- Sportello con finestra in vetro temperato
- Sportelli frontali controbilanciati
- Lampade alogene ad alta resistenza e capacità luminosa

### ACCESSORI

- Cella di lievitazione ermetica
- Supporto del forno
- Modulo cappa

### OPTIONAL

- Vaporiera (assorbimento massimo 1,4 Kw)
- Kit abbattimento vapori e odori con filtro ai carboni attivi (assorbimento massimo 0,7 Kw)
- 4 ruote (h = 16 cm + 2 cm per la cella di lievitazione)
- Piedi per celle di lievitazione (h min = 8 cm / max = 20 cm)

### VERSIONI

- Disponibile in versione **EURO EVO "STAND" EVS8** con 1 - 2 - 3 camere di cottura in acciaio alluminato con piano cottura in refrattario
- Piano di cottura e cielo con resistenze corazzate in acciaio inox

### TECHNICAL SPECIFICATIONS

- 1 - 2 - 3 cooking chambers in full refractory material with high resisting and performing baking floor and ceiling
- Stainless steel armoured heating elements "hy-pe" integrated in the refractory floor and ceiling heating elements exposed
- Digital control panel
- Top and bottom separate power control
- Thermal insulation
- Max cook temp 450 °C
- Adjustable steam exhaust valve
- Single tempered glazed door
- Counter balanced door
- High resistance and efficiency halogen lamps

### ACCESSORIES

- Hermetic prover
- Oven support
- Hood module

### OPTIONALS

- Steam injection system (max. absorption 1,4 Kw)
- Steam and odours damper kit for hood with active carbon filter (max. absorption 0,7 Kw)
- 4 wheels (h = 16 cm + 2 cm for the prover)
- Feet for provers (h min = 8 cm / max = 20 cm)

### VERSIONS

- Available in **EURO EVO "STAND" - EVS8** version with 1 - 2 - 3 cooking chambers in aluminium coated steel plate with refractory cooking floor
- Top and bottom stainless steel armoured heating elements

ITALFORNI È UN BRAND DI WAICO GROUP

ITALFORNI - Sede operativa  
Via dell'Industria, 130 - Loc. Chiusa di Ginestreto  
61122 Pesaro (PU) Italia - Tel. +39 0721 481515  
italforni@waicogroup.com - www.italforni.it

WAICO srl - Sede legale  
Via Scotte, 1 - Isola Vicentina  
36033 Vicenza (VI) Italia - Tel. +39 0445 1716598  
info@waicogroup.com - www.waicogroup.com

**1 CAMERA + SUPPORTO ALTO**  
1 DECK + HIGH STAND

✓ ALLACCIO ELETTRICO  
ELECTRIC CONNECTION

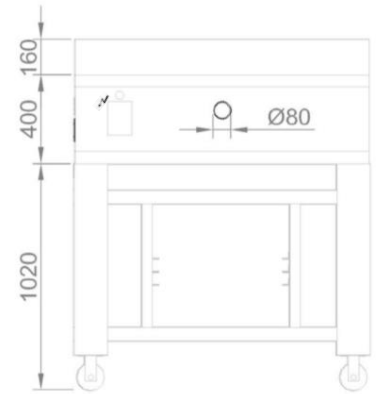
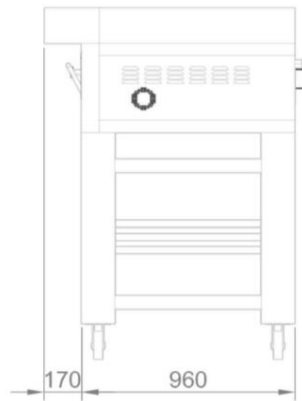

**1 CAMERA + CELLA DI LIEVITAZIONE ALTA**  
1 DECK + HIGH PROVER

✓ ALLACCIO ELETTRICO  
ELECTRIC CONNECTION

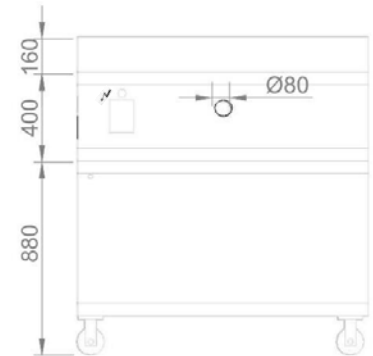
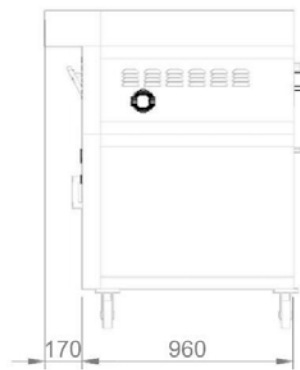
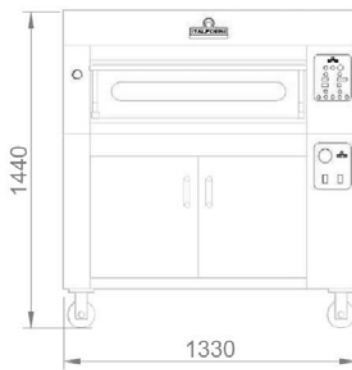

**2 CAMERE + SUPPORTO ALTO**  
2 DECKS + HIGH STAND

✓ ALLACCIO ELETTRICO  
ELECTRIC CONNECTION

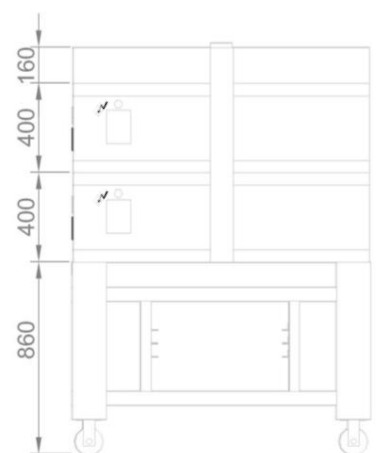
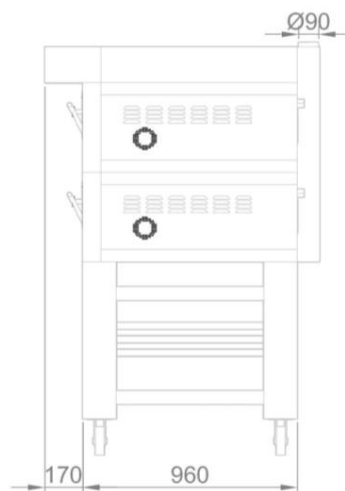
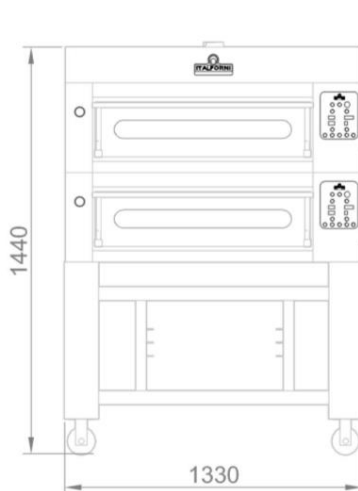

ITALFORNI È UN BRAND  
DI WAICO GROUP

ITALFORNI - Sede operativa  
Via dell'Industria, 130 - Loc. Chiusa di Ginestreto  
61122 Pesaro (PU) Italia - Tel. +39 0721 481515  
italforni@waicogroup.com - www.italforni.it

WAICO srl - Sede legale  
Via Scotte, 1 - Isola Vicentina  
36033 Vicenza (VI) Italia - Tel. +39 0445 1716598  
info@waicogroup.com - www.waicogroup.com

**2 CAMERE + CELLA DI LIEVITAZIONE ALTA**  
**2 DECKS + HIGH PROVER**

ALLACCIO ELETTRICO  
 ELECTRIC CONNECTION

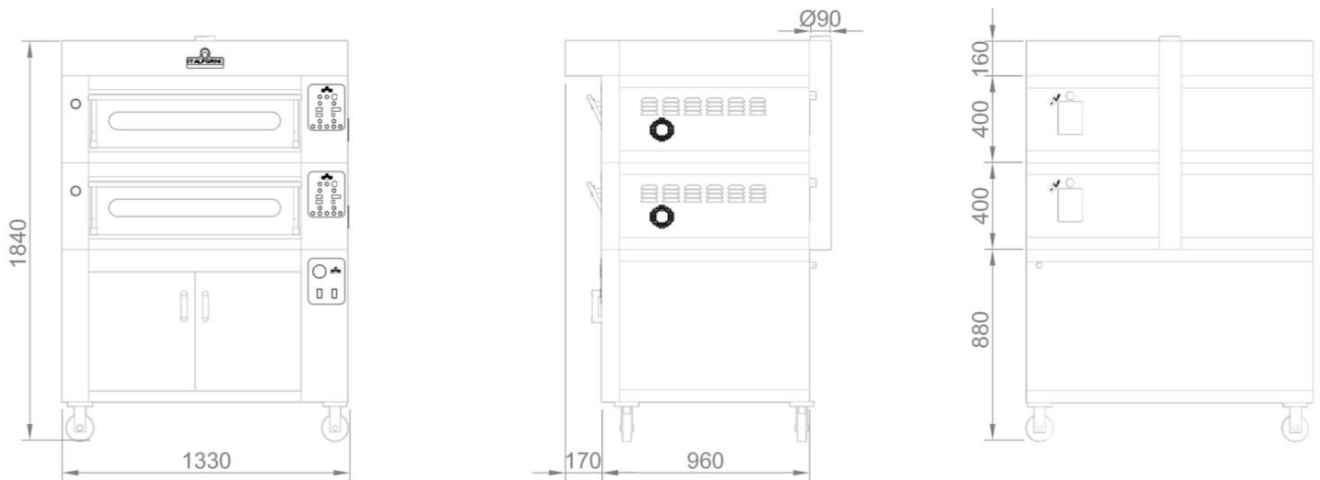

**3 CAMERE + SUPPORTO BASSO**  
**3 DECKS + LOW STAND**

ALLACCIO ELETTRICO  
 ELECTRIC CONNECTION

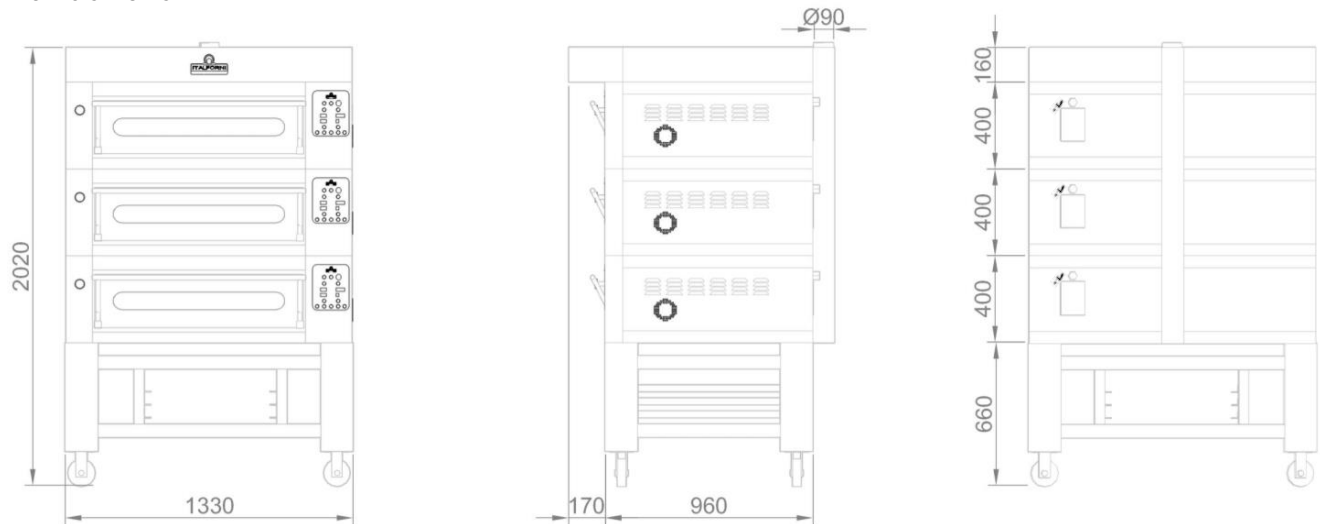

**3 CAMERE + CELLA DI LIEVITAZIONE BASSA**  
**3 DECKS + LOW PROVER**

ALLACCIO ELETTRICO  
 ELECTRIC CONNECTION

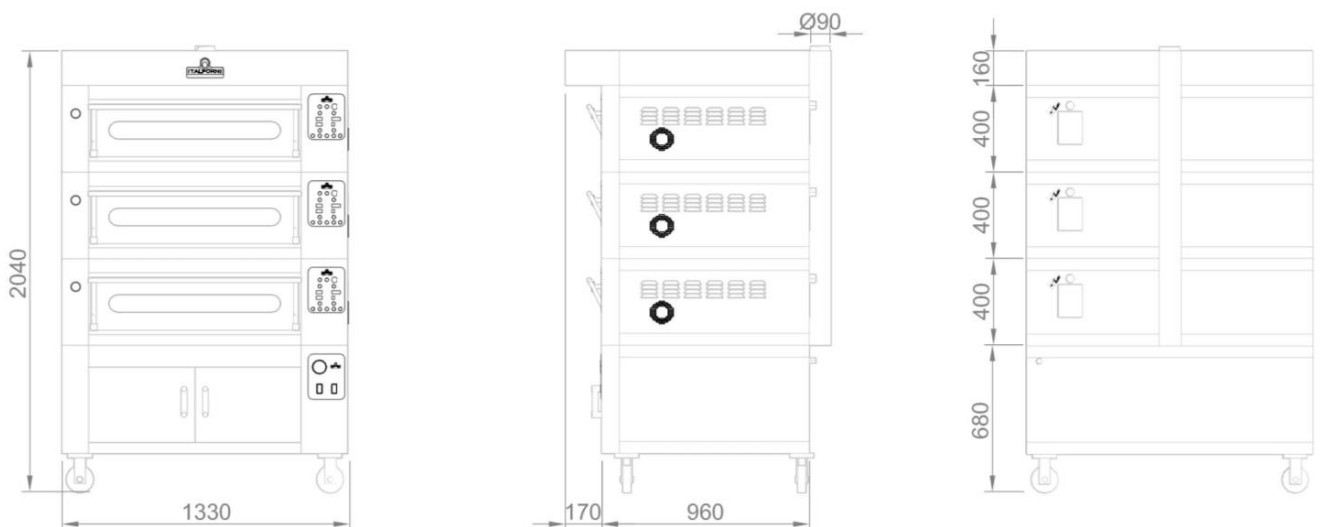

**ITALFORNI È UN BRAND  
 DI WAICO GROUP**

ITALFORNI - Sede operativa  
 Via dell'Industria, 130 - Loc. Chiusa di Ginestreto  
 61122 Pesaro (PU) Italia - Tel. +39 0721 481515  
 italforni@waicogroup.com - www.italforni.it

WAICO srl - Sede legale  
 Via Scotte, 1 - Isola Vicentina  
 36033 Vicenza (VI) Italia - Tel. +39 0445 1716598  
 info@waicogroup.com - www.waicogroup.com

### VALVOLA REGOLABILE PER SCARICO VAPORI ADJUSTABLE STEAM EXHAUST VALVE

Vista dall'alto 1 camera  
Top view 1 deck

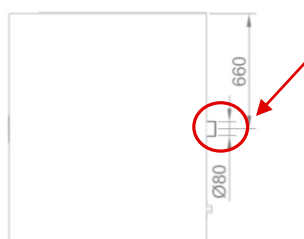

Vista dall'alto 2 o 3 camere  
Top view 2 or 3 decks

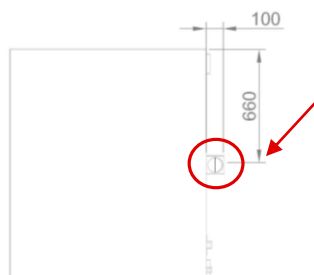

### VAPORIERA STEAM INJECTION SYSTEM

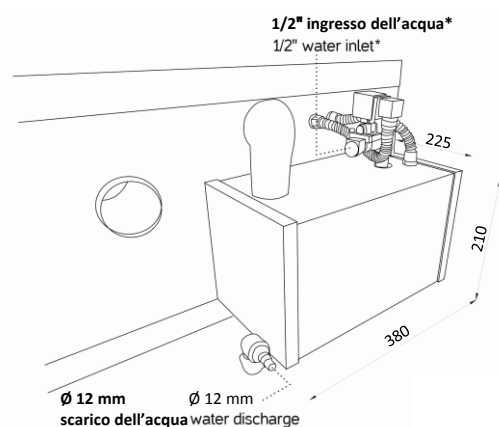

\*Deve essere installato un riduttore di pressione massima di 0.5/0.6 bar  
\*0.5/0.6 bar max pressure reduce has to be installed  
**Assorbimento massimo 1,4 Kw**  
Max. absorption 1,4 Kw

### CAPACITÀ DI CARICO PER CAMERA LOADING CAPACITY PER DECK

EVC8

**DIMENSIONI INTERNE**  
Internal dimensions  
A/H 17 x L/W 93 x P/D 63 cm  
6 Pizze Ø 30 cm  
2 Teglie 60x40 cm  
2 Baking pans 60x40 cm

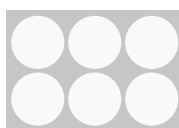

### DATI TECNICI TECHNICAL CHART



Euro	Dimensioni interne (cm)			Dimensioni esterne (cm)			Peso	Alimentazione	Potenza	Potenza	Assorbimento	Temperatura	N° Teglie
	Internal dimensions (cm)			External dimensions (cm)			Weight	Supply	Power	Power	Absorption	Temperature	# Baking pans
	A/H	L/W	P/D	A/H	L/W	P/D	KG	V/Ph/Hz	KW	KW/h	Ampere	°C	60x40 cm
EVC8 - DECK	17	93	63	40	132	96	176	400/3/50-60	7,3	3,8	12	0/450	
KVC8 - HOOD				16	132	113	30						
BVC8 - PROVER				70/50	132	96	70/55	230/1/50-60	1	0,5		0/90	14/6
SEVC8 - STAND				86/70/50	133	96	49/44/37						16/6/6

ITALFORNI È UN BRAND  
DI WAICO GROUP

ITALFORNI - Sede operativa  
Via dell'Industria, 130 - Loc. Chiusa di Ginestreto  
61122 Pesaro (PU) Italia - Tel. +39 0721 481515  
italforni@waicogroup.com - www.italforni.it

WAICO srl - Sede legale  
Via Scotte, 1 - Isola Vicentina  
36033 Vicenza (VI) Italia - Tel. +39 0445 1716598  
info@waicogroup.com - www.waicogroup.com

I dati riportati sul presente documento sono da ritenersi non vincolanti. Waico srl si riserva di apportare modifiche tecniche in qualsiasi momento.  
The specifics shown in this document are to be considered not binding. Waico srl reserves the right to make technical changes at any moment.