

EURO EVO

Forno elettrico modulare per pizzeria, pasticceria e panetteria

Modular electric oven for pizza, pastry and bread



EURO EVO STAND - EVS12

CARATTERISTICHE TECNICHE

- 1 - 2 - 3 camere di cottura interamente in acciaio alluminato con piano cottura in refrattario
- Piano di cottura e cielo con resistenze corazzate in acciaio inox
- Pannello di controllo elettromeccanico (opzione digitale su richiesta)
- Controllo delle temperature del piano di cottura e del cielo separate
- Isolamento termico
- Massima temperatura di cottura 450 °C
- Valvola regolabile per scarico vapori
- Sportello con finestra in vetro temperato
- Sportelli frontali controbilanciati
- Lampade alogene ad alta resistenza e capacità luminosa

ACCESSORI

- Cella di lievitazione ermetica
- Supporto del forno
- Modulo cappa

OPTIONAL

- Pannello di controllo digitale
- Vaporiera (assorbimento massimo 1,4 Kw)
- Kit abbattimento vapori e odori con filtro ai carboni attivi (assorbimento massimo 0,7 Kw)
- 4 ruote (h = 16 cm + 2 cm per la cella di lievitazione)
- Piedi per celle di lievitazione (h min = 8 cm / max = 20 cm)

TECHNICAL SPECIFICATIONS

- 1 - 2 - 3 cooking chambers in aluminium coated steel plate with refractory cooking floor
- Top and bottom stainless steel armored heating elements
- Electromechanical control panel (digital optional by request)
- Top and bottom separate temperature control
- Thermal insulation
- Max cook temp 450 °C
- Adjustable steam exhaust valve
- Single tempered glazed door
- Counter balanced door
- High resistance and efficiency halogen lamps

ACCESSORIES

- Hermetic proofer
- Oven support
- Hood module

OPTIONALS

- Digital control panel
- Steam injection system (max. absorption 1,4 Kw)
- Steam and odours damper kit for hood with active carbon filter (max. absorption 0,7 Kw)
- 4 wheels (h = 16 cm + 2 cm for the proofer)
- Feet for provers (h min = 8 cm / max = 20 cm)

VERSIONI

- Resistenze corazzate in acciaio inossidabile integrate nel refrattario del piano di cottura
- Disponibile in versione **EURO EVO "CLASSIC" - EVC12** con 1 - 2 - 3 camere di cottura in materiale refrattario con piano cottura e cielo ad alte prestazioni e resistenza

VERSIONS

- Stainless steel armoured heating elements integrated in the refractory floor
- Available in **EURO EVO "CLASSIC" - EVC12** version with 1 - 2 - 3 cooking chambers in full refractory material with high resisting and performing baking floor and ceiling

ITALFORNI È UN BRAND DI WAICO GROUP

ITALFORNI - Sede operativa
Via dell'Industria, 130 - Loc. Chiusa di Ginestreto
61122 Pesaro (PU) Italia - Tel. +39 0721 481515
italforni@waicogroup.com - www.italforni.it

WAICO srl - Sede legale
Via Scotte, 1 - Isola Vicentina
36033 Vicenza (VI) Italia - Tel. +39 0445 1716598
info@waicogroup.com - www.waicogroup.com



I dati riportati sul presente documento sono da ritenersi non vincolanti. Waico srl si riserva di apportare modifiche tecniche in qualsiasi momento.
The specifics shown in this document are to be considered not binding. Waico srl reserves the right to make technical changes at any moment.

1 CAMERA + SUPPORTO ALTO
1 DECK + HIGH STAND

✓ ALLACCIO ELETTRICO
ELECTRIC CONNECTION

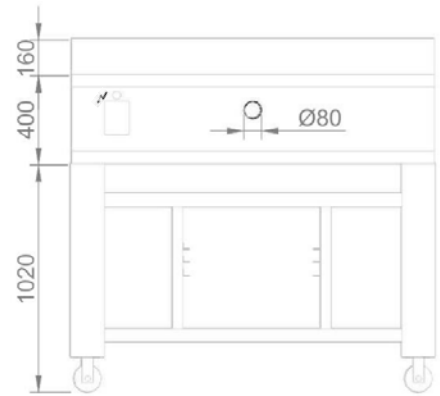
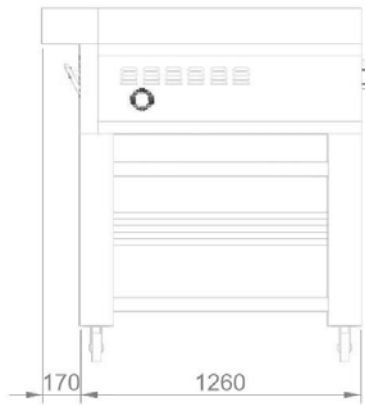
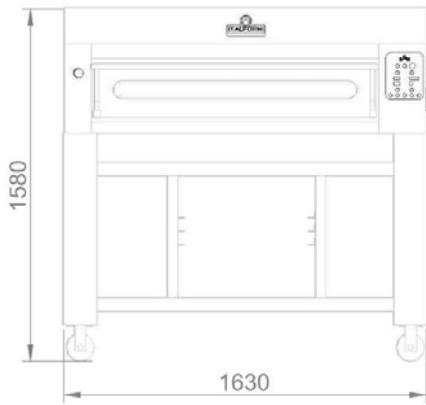

1 CAMERA + CELLA DI LIEVITAZIONE ALTA
1 DECK + HIGH PROVER

✓ ALLACCIO ELETTRICO
ELECTRIC CONNECTION

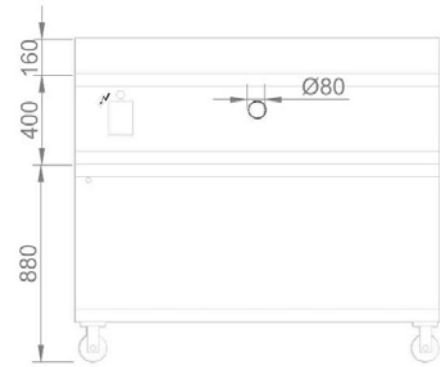
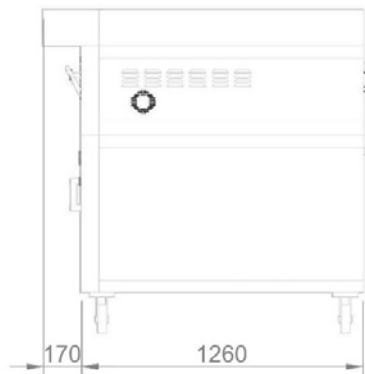
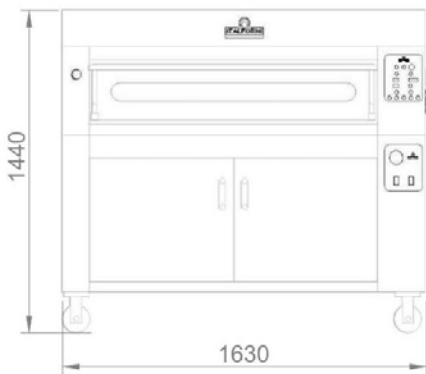

2 CAMERE + SUPPORTO ALTO
2 DECKS + HIGH STAND

✓ ALLACCIO ELETTRICO
ELECTRIC CONNECTION

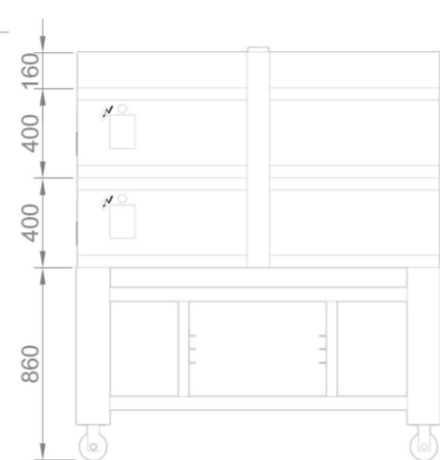
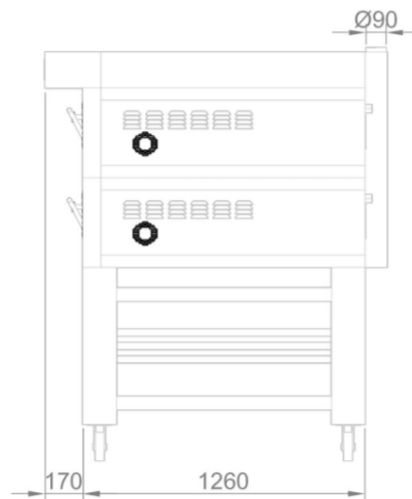
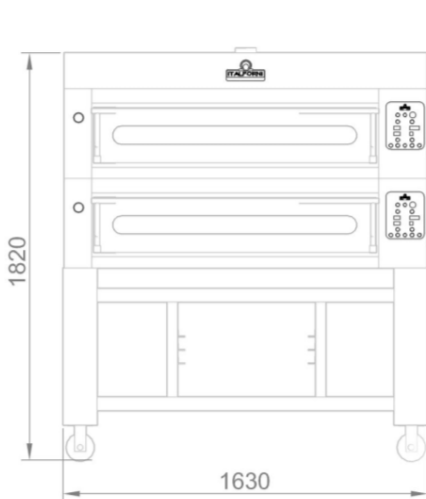

ITALFORNI È UN BRAND
DI WAICO GROUP

ITALFORNI - Sede operativa
Via dell'Industria, 130 - Loc. Chiusa di Ginestreto
61122 Pesaro (PU) Italia - Tel. +39 0721 481515
italforni@waicogroup.com - www.italforni.it

WAICO srl - Sede legale
Via Scotte, 1 - Isola Vicentina
36033 Vicenza (VI) Italia - Tel. +39 0445 1716598
info@waicogroup.com - www.waicogroup.com

2 CAMERE + CELLA DI LIEVITAZIONE ALTA
2 DECKS + HIGH PROVER

ALLACCIO ELETTRICO
 ELECTRIC CONNECTION

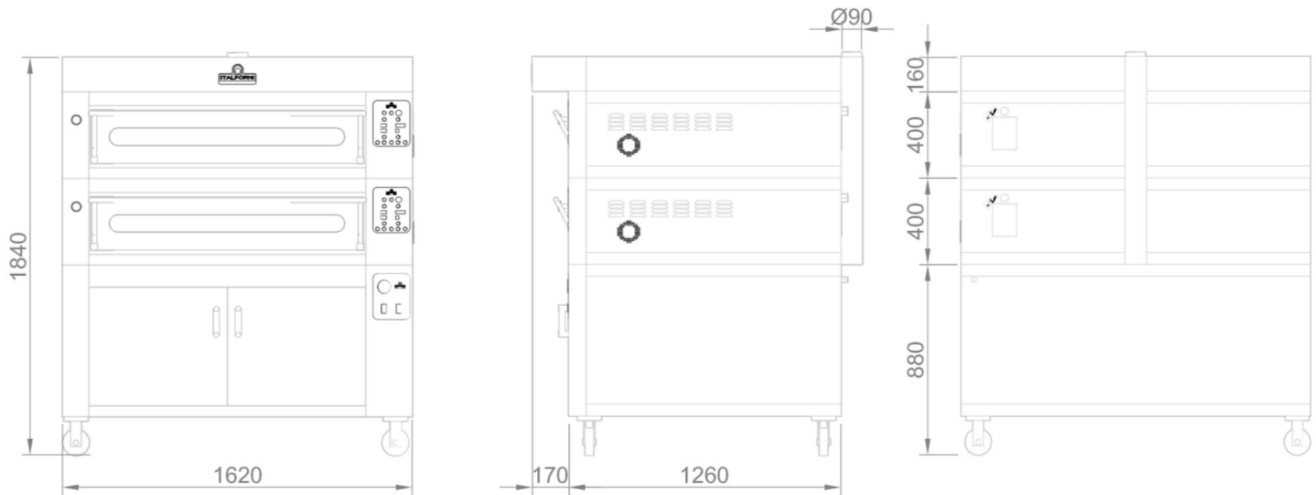

3 CAMERE + SUPPORTO BASSO
3 DECKS + LOW STAND

ALLACCIO ELETTRICO
 ELECTRIC CONNECTION

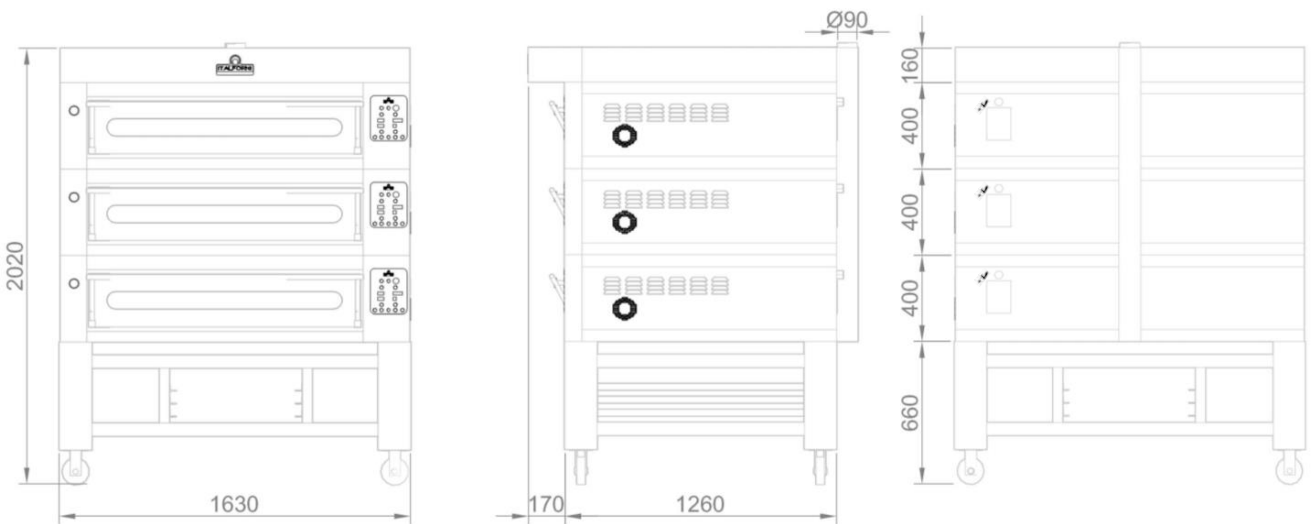

3 CAMERE + CELLA DI LIEVITAZIONE BASSA
3 DECKS + LOW PROVER

ALLACCIO ELETTRICO
 ELECTRIC CONNECTION

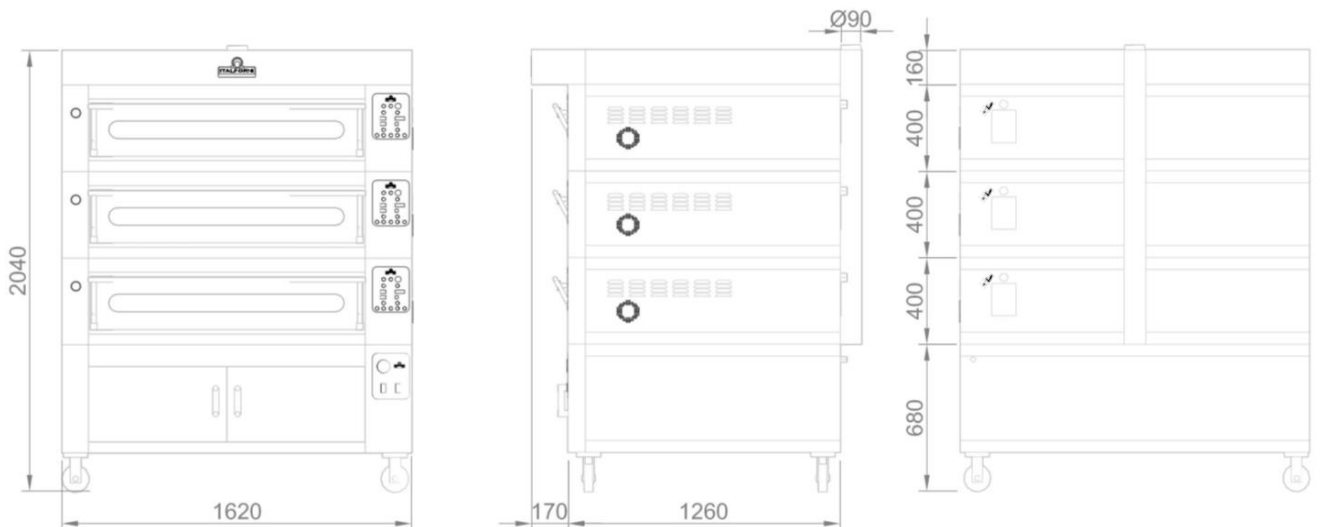

**ITALFORNI È UN BRAND
 DI WAICO GROUP**

ITALFORNI - Sede operativa
 Via dell'Industria, 130 - Loc. Chiusa di Ginestreto
 61122 Pesaro (PU) Italia - Tel. +39 0721 481515
 italforni@waicogroup.com - www.italforni.it

WAICO srl - Sede legale
 Via Scotte, 1 - Isola Vicentina
 36033 Vicenza (VI) Italia - Tel. +39 0445 1716598
 info@waicogroup.com - www.waicogroup.com

VALVOLA REGOLABILE PER SCARICO VAPORI ADJUSTABLE STEAM EXHAUST VALVE

Vista dall'alto 1 camera
Top view 1 deck

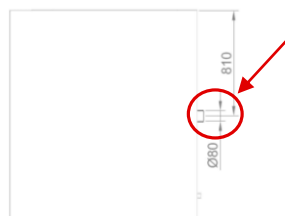

Vista dall'alto 2 o 3 camere
Top view 2 or 3 decks

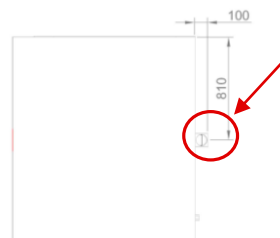

VAPORIERA STEAM INJECTION SYSTEM

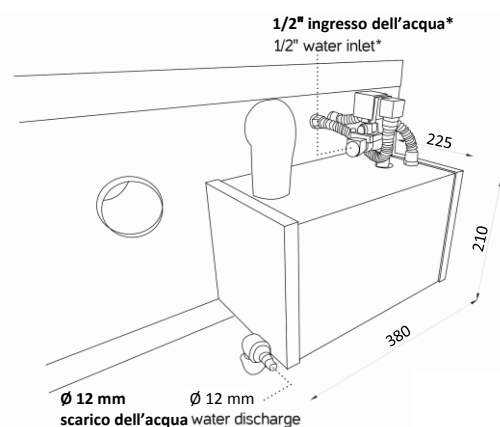

*Deve essere installato un riduttore di pressione massima di 0.5/0.6 bar
*0.5/0.6 bar max pressure reduce has to be installed
Assorbimento massimo 1,4 Kw
Max. absorption 1,4 Kw

CAPACITÀ DI CARICO PER CAMERA LOADING CAPACITY PER DECK

EVC12
EVS12

DIMENSIONI INTERNE
Internal dimensions
A/H 17 x L/W 123 x P/D 93 cm
12 Pizze Ø 30 cm
4 Teglie 60x40 cm
4 Baking pans 60x40 cm

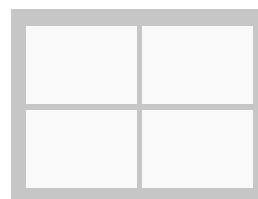
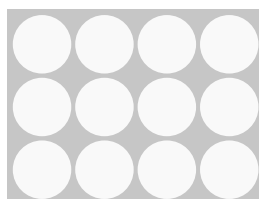

DATI TECNICI TECHNICAL CHART



Euro	Dimensioni interne (cm)			Dimensioni esterne (cm)			Peso	Alimentazione	Potenza	Potenza	Assorbimento	Temperatura	N° Teglie
	Internal dimensions (cm)			External dimensions (cm)			Weight	Supply	Power	Power	Absorption	Temperature	# Baking pans
	A/H	L/W	P/D	A/H	L/W	P/D	KG	V/Ph/Hz	KW	KW/h	Ampere	°C	60x40 cm
EVC12 / EVS1 - DECK	17	123	93	40	162	126	260/220	400/3/50-60	12,5	6	20	0/450	
KVC12 / KVS12 - HOOD				16	162	143	45						
BVC12 / BVS12 - PROVER				70/50	162	126	120/105	230/1/50-60	1	0,5		0/90	28/12
SEVC12 / SEVS12 - STAND				86/70/50	163	126	56/51/44						24/9/9

ITALFORNI È UN BRAND
DI WAICO GROUP

ITALFORNI - Sede operativa
Via dell'Industria, 130 - Loc. Chiusa di Ginestreto
61122 Pesaro (PU) Italia - Tel. +39 0721 481515
italforni@waicogroup.com - www.italforni.it

WAICO srl - Sede legale
Via Scotte, 1 - Isola Vicentina
36033 Vicenza (VI) Italia - Tel. +39 0445 1716598
info@waicogroup.com - www.waicogroup.com

I dati riportati sul presente documento sono da ritenersi non vincolanti. Waico srl si riserva di apportare modifiche tecniche in qualsiasi momento.
The specifics shown in this document are to be considered not binding. Waico srl reserves the right to make technical changes at any moment.